

# MOTOR BFDE 5.0CV

70502



Tipo	Diesel 4T, Refrigerado a Ar
Potência Máxima (Cv)(KW/Rpm)	5,0 (3,7/3600)
Potência Reg. Contínuo (Cv)(KW/Rpm)	3,8 (2,8/3600)
Torque Máximo (kgfm/rpm)	1,30/2.500
Cilindrada (cm³)	219
Diâmetro do Cilindro (mm)	70
Curso do Pistão (mm)	57
Eixo - Diâm. X Comp. (pol/mm)	Ø3/4"(19,05) X 61,5
Taxa de Compressão	20,5:1
Reservatório do Cáster (L)	0,75 / SAE 15W40
Capacidade do Tanque (L)	2,5 / Diesel S500
Consumo Médio (L/h)	1,4
Sistema de Alimentação (Tipo)	Injeção Mecânica
Sistema de Ignição	Compressão
Sistema de Partida	Elétrica e Manual
Sistema de Lubrificação (Tipo)	Forçado por Bomba
Filtro de Ar (Tipo)	Elemento de Papel
Dimensões CxLxA (mm)	450x430x480
Peso Bruto (kg)	26,4
Peso Líquido (kg)	23,4



## Anéis-Pistão-Biela

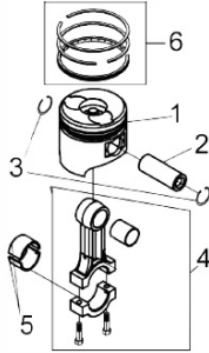

Ref.	Cód	Descrição	Qtd Prod
1	108	PISTAO STD/D 5.0	1
2	111	PINO DO PISTAO	1
3	105	ANEL TRAVA PINO PIST 19/D	2
4	114	CONJUNTO BIELA	1
5	117	BRONZINA BIELA JG/D	1
6	98	JOGO DE ANEIS/D 5.0	1
7	5875	PARAF DA BIELA/D	2

## Bloco Cilindro

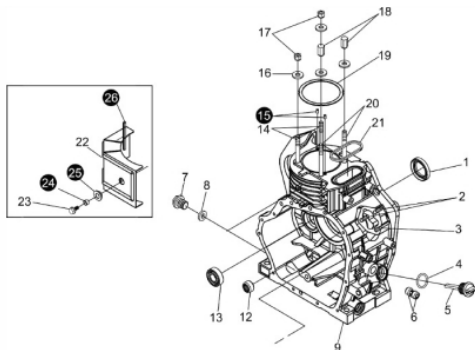

Ref.	Cód	Descrição	Qtd Prod
1	26	RETENTOR 30x45x8/D	1
2	252	PRIS BOMBA INJETORA/D	2
3	253	PRIS.BOMBA M6X1X18mm	1
4	30	ANEL O-RING 19X2.65/D	2
5	32	BUJAO NIVEL OLEO/D	2
6	254	ROL EIXO RAR/D	2
7	28	BUJAO DRENO OLEO/D	2
8	29	JUNTA BUJAO DRENO/D	2
9	23	CARCACA-CILINDRO/D	1
10	255	CHAPA TRAVA ROL/D	1
11	258	PARAF M8X1.25X14- ZN AM	1
12	36	ROL AGULHAS/D	1
13	123	ROL ESF 6202P6/D	2
14	259	PRIS.CILINDRO CURTO	2
16	266	ARRUELA CABECOTE D5.0	4
17	12	PORCA M8X1.25- SX ZN AM	2
18	11	PORCA M8X1.25- SX ZN AM	2
19	17	JUNTA CABECOTE/D	1
20	262	PRIS.CILINDRO LONGO	2
21	20	ANEL O-RING RETANG D5.0	1
22	269	CHAPA DEFLETORA D5.0	1
23	409	PARAF M6X1X12MM- ZN AM	1

## Cabeçote

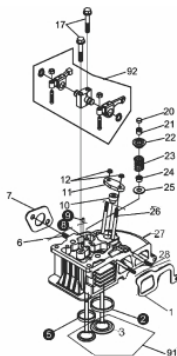

Ref.	Cód	Descrição	Qtd Prod
1	236	JUNTA COLETOR ADMISSAO/D	1
6	284	PRIS ESCAPE/D	2
7	239	JUNTA ESCAPE/D	1
10	295	CALCO AJUSTE BICO INJETOR	1
11	296	CHAPA TRAVA BICO INJET/D	1
12	357	PORCA M6X1- SX ZN AM	2
17	61	PARAF M6X1X45MM- ZN AM	2
20	63	PASTILHA AJUSTE VALVULA/D	2
21	66	TRAVA PRATO VALVULA/D	4
22	69	PRATO MOLA VALVULA/D	2
23	72	MOLA DA VALVULA/D	2
24	75	RETENTOR GUIA VALVULA/D	2
25	78	ASSENTO MOLA VALVULA/D	2
26	90	PRIS BICO INJETOR/D	2
27	81	CABECOTE D5.0	1
28	91	PRIS BICO INJETOR/D	2
30	1560	ARRUELA CALCO BICO INJ/D	1
91	84	CONJ VALVULA ADMI-ESCAP/D	1



Ref.	Cód	Descrição	Qtd Prod
92	92	CONJ BALANCIM D5.0/7.0	1

### Carenagem

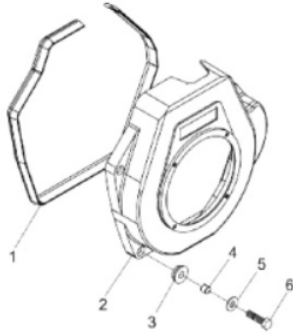

Ref.	Cód	Descrição	Qtd Prod
1	228	PERFIL VED.CARENAGEM	1
2	224	CARENAGEM D5.0	1
3	227	COXIM CARENAGEM/D	4
4	415	PINO CENTRALIZ CARE/D	4
5	416	ARRUELA LISA M6 - ZN AM/D	4
6	417	PARAF M6X1.0X22MM- ZN AM	4

### Comando de Válvula

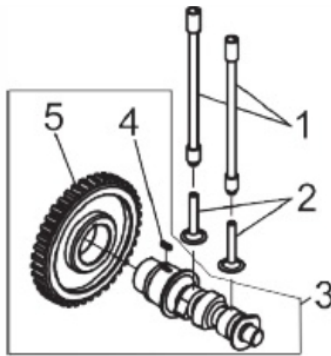

Ref.	Cód	Descrição	Qtd Prod
1	144	VARETA VALVULA/D	2
2	147	TUCHO VALVULA/D	2
3	149	EIXO COMANDO VALVULA/D	1
4	321	CHAVETA 5X14/D	1
5	152	ENGR EIXO COMANDO VALV/D	1

### Componentes Partida Elétrica Motor

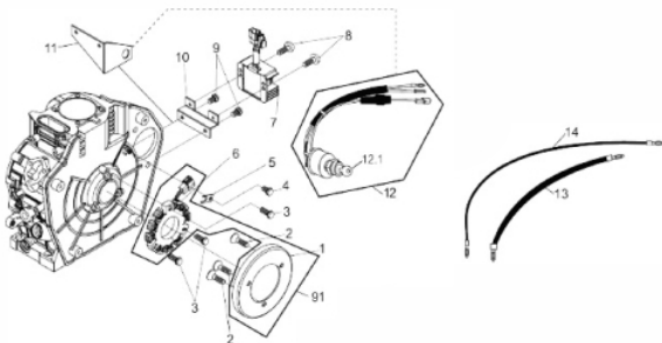

Ref.	Cód	Descrição	Qtd Prod
2	407	PARAF VOLANTE M6X10-ZN AM	3
3	408	PARAF M6X1X20MM- ZN AM	3
4	409	PARAF M6X1X12MM- ZN AM	1
5	410	CHAPA TRAVA FIO P.E./D	1
7.1	232	REGULADOR TENSAO -4	1
7.2	6950	REGULADOR TENSAO -3	1
8	412	PARAF M6X1X12MM- ZN AM	2
9	413	PARAF M6X1X14MM- ZN AM	2
10	414	CHAPA FIXACAO	1
11	943	SUP. CHAVE IGNICAO/D	1
12	553	CONJ CHAVE/CHICOTE	1
12.a	1189	CHAVE DE PARTIDA/D	1
13	939	CABO NEGATIVO 740MM/D	1
14	940	CABO POSITIVO 370MM/D	1
91	104	ALTERNADOR COMPLETO	1



Conjunto Aceleração RAR

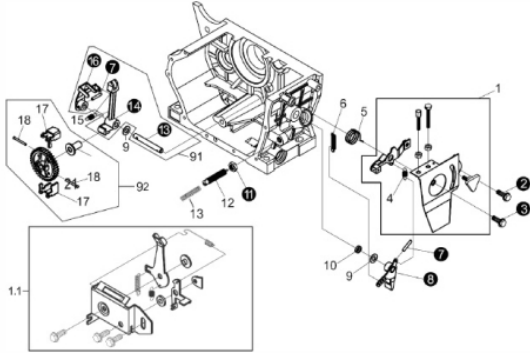

Ref.	Cód	Descrição	Qtd Prod
1	401	CONJ ACELERACAO/D	1
4	382	MOLA CURTA RAR/D	1
5	383	MOLA RETORNO	1
6	384	MOLA LONGA RAR/D	1
9	388	ARRUELA EIXO RAR/D	2
10	389	RETENTOR 8X14X3MM	1
12	391	PARAF LIMITADOR ROTACAO/D	1
13	2842	MOLA PARAF.REG.ROT./D	1
15	395	MOLA ACIONAMENTO RAR/D	1
17	1747	CONTRAPESO DO RAR/D	2
18	1748	PINO CONTRAPESO RAR/D	2
19	399	DESLIZADOR RAR/D	1
20	1746	ENGR RAR/D	1
21	6568	TUCHO RAR	1
91	392	CONJ ACIONAMENTO RAR/D	1
92	1744	CONJ ENGREN RAR/D	1

Conjunto Bico Injetor

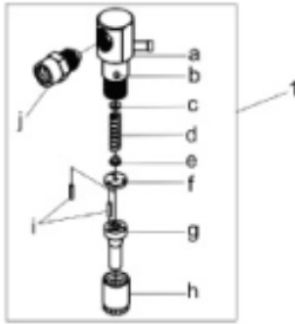

Ref.	Cód	Descrição	Qtd Prod
1	158	BICO INJETOR/D	1
g	794	KIT INJETOR	1

Conjunto Bomba Injetora

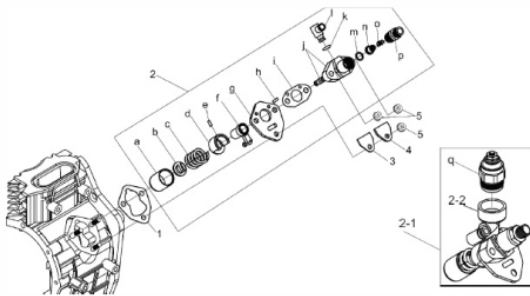

Ref.	Cód	Descrição	Qtd Prod
1.1	2141	JUNTA BOMBA INJ. 0.10MM/D	2
1.2	2835	JUNTA BOMBA INJ. 0.20MM/D	2
1.3	2836	JUNTA BOMBA INJ. 0.30MM/D	2
1.4	31	JUNTA BOMBA INJ. 0.50MM/D	2
2	177	BOMBA INJETORA D5.0	1
a	143	TUCHO BOMBA INJETORA/D	1
3	34	JUNTA CHAPA SELO/D	1
4	35	CHAPA SELO/D	1
5	357	PORCA M6X1- SX ZN AM	3
d	1451	GUIA ALAVANCA BOMBA INJ/D	1
e	1452	PINO TRAVA BOMBA INJET./D	1
k	5753	ANEL O-RING 10MM	1

Escape

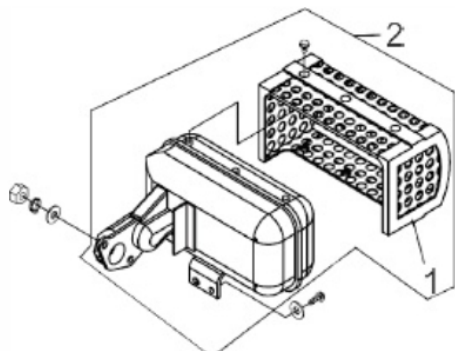

Ref.	Cód	Descrição	Qtd Prod
1	249	PROTECTOR ESCAPE/D	1
2	101	ESCAPE COMPLETO	1
	3948	DIRECIONADOR DE FUMACA/D	1



Filtro de ar

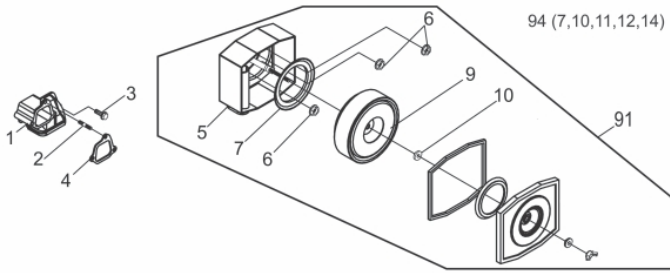

Ref.	Cód	Descrição	Qtd Prod
1	241	COLETOR ADMISSAO/D	1
2	332	PRIS SUPORTE FILTRO AR/D	1
3	333	PARAF M6X1X22MM- ZN AM	1
4	244	JUNTA FILTRO AR/D	1
9	342	ELEM FILTRO AR 5.0/7.0/D	1
91	60	CONJ FILTRO DE AR/D	1
94	3024	JOGO JUNTAS FILTRO AR/D	1
10	4013	COXIM ELEMENTO FILTRO AR	1

Motor de Partida

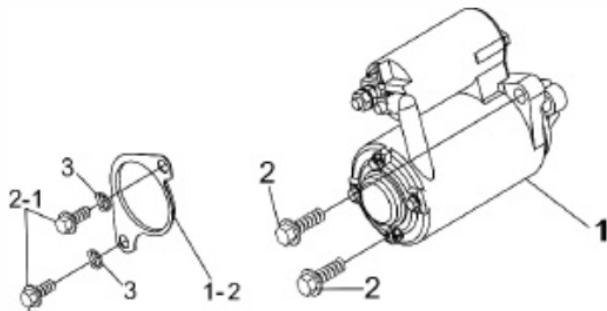

Ref.	Cód	Descrição	Qtd Prod
1	230	MOTOR DE PARTIDA/D - PLUS	1
1-2	402	CHAPA PARTIDA ELETRICA/D	1
2	403	PARAF M10X1.5X30MM- ZN AM	2
2.1	404	PARAF M10X1.5X20MM- ZN AM	2
3	405	ARRUELA DE PRESSAO M10	2

Retrátil

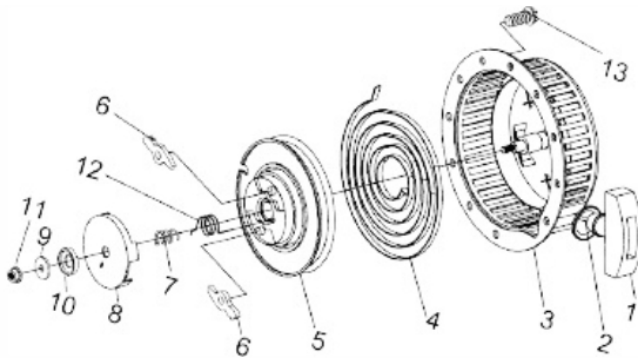

Ref.	Cód	Descrição	Qtd Prod
1	201	PUNHO ARRANQUE/D	1
2	874	CORDA RETRATIL	1
3	196	CARCACA RETRATIL/D	1
4	203	MOLA RETRATIL/D	1
5	205	CARRETEL RETRATIL/D	1
6	208	CACHORRETE/D	1
7	210	MOLA CACHORRETE/D	1
8	214	GUIA CACHORRETE/D	1
10	218	ARRUELA PARTIDA RETR./D	1
11	1331	PORCA M10X1.25 SX FL	1
12	212	MOLA TORQUE/D	1
13	190	PARAF M6X1X8MM- ZN AM	4
	88	RETRATIL COMPLETO/D	1

Sistema de Lubrificação

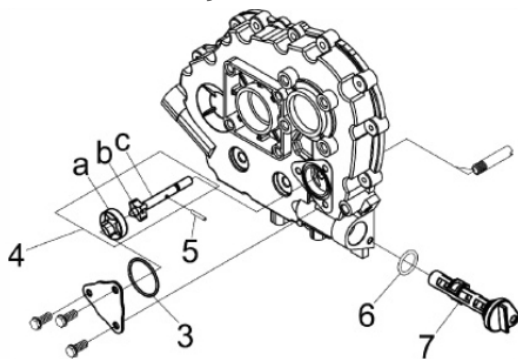

Ref.	Cód	Descrição	Qtd Prod
4	811	BOMBA OLEO LUBRIF/D	1
6	30	ANEL O-RING 19X2.65/D	1
7	188	FILTRO OLEO LUBRIFICANT/D	1



## Tampa do Bloco

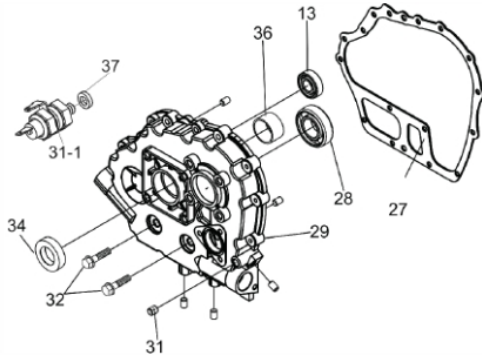

Ref.	Cód	Descrição	Qtd Prod
13	123	ROL ESF 6202P6/D	1
27	40	JUNTA TAMPA CARCACA/D	1
28	37	ROL ESF 6205 C3 VIRABRE/D	1
29	43	TAMPA CARCACA/D	1
31	279	BUJAO G 1/8 TAMPA/D	1
31-1	1185	SENSOR OLEO/D	1
32	280	PARAF M8X1.25X38MM- ZN AM	1
33	281	PARAF M6X1X28MM- ZN AM	14
34	46	RETENTOR 25x42x10/D	1
36	49	BRONZINA MANCAL/D	1
37	1479	ARRUELA DE BORRACHA/D	1
	829	JOGO DE JUNTAS BFD 5.0	1

## Tampa do Cabeçote

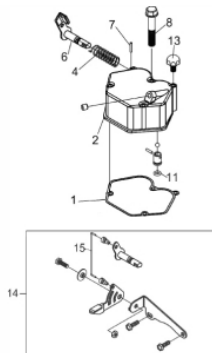

Ref.	Cód	Descrição	Qtd Prod
1	57	JUNTA TAMPA CABECOTE/D	1
2	54	TAMPA CABECOTE/D	1
4	56	MOLA DO DESCOMPRESSOR/D	1
6	52	ALAVANCA	1
7	309	PINO ELAS 3X16 CAB/D	1
8	94	PRIS TAMPA DE VALVULA/D	3
11	53	ANEL O-RING 10X1,9/D	1
13	93	BUJAO TAMPA CABECOTE/D	1

## Tanque Combustível

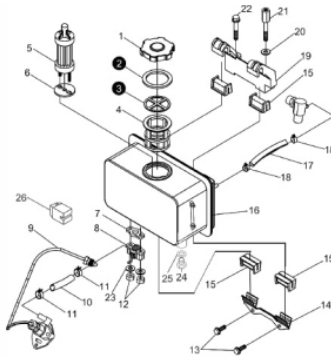

Ref.	Cód	Descrição	Qtd Prod
1	185	TAMPA TANQUE COMB.	1
1	2873	TAMPA TANQUE COMB.	1
4	183	PENEIRA TANQUE/D	1
5	174	ELEM FILTRANTE COMBUST/D	1
6	173	JUNTA FILTRO COMB/D	1
7	170	ANEL VEDACAO TORNEIRA/D	1
8	168	TORNEIRA COMBUSTIVEL/D	1
9	180	TUBO COMBUST ALTA	1
10	172	MANGUEIRA COMBUSTIVEL/D	1
11	171	ANEL ELASTICO 13MM/D	2
12	357	PORCA M6X1- SX ZN AM	2
13	413	PARAF M6X1X14MM- ZN AM	2
14	167	SUP. INFERIOR TANQUE/D	1
15	163	COXIM TANQUE/D	4
16	164	TANQUE COMB.-TRAVA/D	1
17	162	MANGUEIRA RETORNO COMB.	1
18	161	ANEL ELASTICO/D	2
19	155	SUPORTE FIX.TANQUE	1
20	359	ARRUELA M8- ZN AM	1
21	360	PARAF M8X1.25X20MM- ZN AM	1
22	361	PARAF M8X1.25X45MM- ZN AM	1
23	362	ARRUELA M6 - ZN AM/D	2
24	1522	PARAF M12X1.25X15MM-ZN AM	1
25	1523	ARRUELA NYLON DRENO TQ/D	1
26	2139	COXIM TUBO DE	1



Volante - Virabrequim

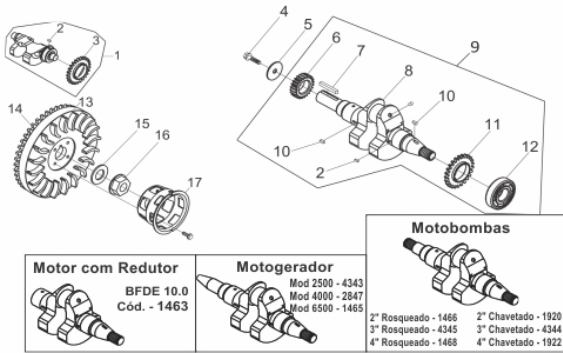

Ref.	Cód	Descrição	Qtd Prod
1	4562	EIXO BALANCIADOR	1
2	313	CHAVETA EIXO BALANC/D	2
3	128	ENGR EIXO BALANCEADOR/D	1
4	314	PARAF 5/16"X30MM- ZN AM	1
5	316	ARRUELA LISA EIXO VIRAB/D	1
6	131	ENGR MOTRIZ COMANDO	1
7	318	CHAVETA 4.76X30MM/D	1
8	4342	EIXO VIRABREQ H/D 5.0	1
10	320	CHAVETA 5X12/D	2
11	137	ENGR MOTRIZ EIXO BALANC/D	1
12	322	ROL ESF 6306 P5/D	1
13	140	VOLANTE/D	1
14	233	COROA DE PARTIDA/D	1
15	325	ARRUELA VOLANTE/D	1
16	327	PORCA M16X1.25 SEX PR	1
17	221	CUBO PARTIDA/D	1